



Lockheed Martin Aeronautics Company

REVISION 26

CONTROLLED AND APPROVED BY:

**Lockheed Martin Aeronautics Company
Supplier Quality Management
April 2010**

IMPORTANT NOTICE: A hard copy of this document may not be the

* REVISED

** ADDED

TABLE OF CONTENTS

TABLE OF CONTENTS (cont'd.)

PART III. INTERNATIONAL SELLER REQUIREMENTS

1.0	GENERAL	Page	25
2.0	CONTROL OF SUPPORT EQUIPMENT (SE), MANUFACTURING TEST EQUIPMENT (MTE) AND SPECIAL TEST EQUIPMENT (STE)	Page	25
3.0	CHANGE AUTHORIZATION	Page	26
4.0	TOOLING PRACTICES FOR BUYER-FURNISHED TOOLS	Page	26
5.0	LISTINGS OF SELLER-FABRICATED/PROCURED ST OR STE	Page	26
6.0	DRAWINGS, SKETCHES, TOOL DESIGNS, ETC.	Page	26
7.0	CALIBRATION AND RE-CALIBRATION OF BUYER-FURNISHED OR SELLER-FABRICATED STE	Page	26
8.0	TOOLING USE AND TOLERANCE REQUIREMENTS	Page	27
9.0	QUALITY ASSURANCE REQUIREMENTS OF SELLER-OWNED OR SELLER-FABRICATED	Page	27

PART I

AIRCRAFT ITEMS AND TOOLING - SELLER REQUIREMENTS

1.0 GENERAL

2.5 STE means either single or multipurpose integrated test Items engineered, designed, fabricated or modified to accomplish special purpose testing. STE consists of Items that are interconnected and interdependent so as to become a new functional entity for special testing purposes. STE excludes:

- Consummable property
- ST
- Facility Items (except necessary improvements for installing STE)
- Plant equipment Items used for general plant testing purposes

2.6 MSE is used in manufacturing operations to support, test or prove the functional operation of an Item.

2.7 MSE consists of the following types of Items and shall be considered United States ("U.S.") Government property:

2.7.1 SE required to make an Item operational in its intended environment. SE includes the following:

- Common and Standard SE – For use on more than one type Item
- Peculiar or Non-Standard SE – For use on a peculiar or specific Item

2.7.2 MTE required for use in manufacturing operations to conduct tests and/or prove the functional operation of a specific Item. MTE is peculiar to manufacturing in that it is not normally used by Buyer to support the Item in an operational environment.

2.8 "Control Media" means tooling and electronic data used to control I/R and/or coordinating points and are categorized as follows:

2.8.1 "Master Tooling" – Master tool gages used to establish dimensions and features during manufacture of Production Tools which control I/R and/or coordination points of production Items. Unless Buyer has provided Seller with prior specific written authorization to do so, Seller shall not use Master Tooling for production purposes, i.e., Item verification, drilling, trimming or forming.

2.8.2 "Controlled Production Tooling" – Tooling such as jigs and fixtures used to establish dimensions and features of Items and which control I/R and/or coordination points of those Items.

2.8.3 "Electronic Data" – Computer-generated electronic data used to establish dimensions and features during manufacture of production Items.

* 2.12 Electronic Supplier Problem and Resolution (“e-SPaR”) - This online system is available on the Buyer’s Supply Chain Management Homepage at <http://www.lockheedmartin.com/aeronautics/materialmanagement> and is the approved system for Seller to request information regarding PO requirements, including Engineering drawing clarifications, tool design clarifications and any related issue that does not pertain to a physical discrepancy within a tool.

2.13 Seller Aircraft Tooling Report (“SATR”)

2.13.1 This online system is available on the Buyer’s Supply Chain Management Homepage and to provides Seller with a traceable electronic means of reporting ST discrepancies and achieving

means (bolts, nuts, screws, pins, etc.) to install. Interchangeable Items do not require any fabrication operations such as cutting, filing, drilling, hammering or forcing at the point of installation.

3.3 "Replaceable Items" – Replaceable Items are partially finished and have designed/controlled features which require alteration of the Items in addition to the normal application and/or methods of attachment at the point of installation. Such alterations are limited to specified areas and may include drilling, filing, trimming, bending, etc.

3.4 "Interchangeable Category Items" – Items so 60 TDme

stated atypical Items)6(whi



Figure 2. Example of I/R Wear Groove Indicators

3.8 Seller shall identify I/R Holes with a 1/8" band of red paint around each hole or group of holes as illustrated in Figure 3 and Figure 4.

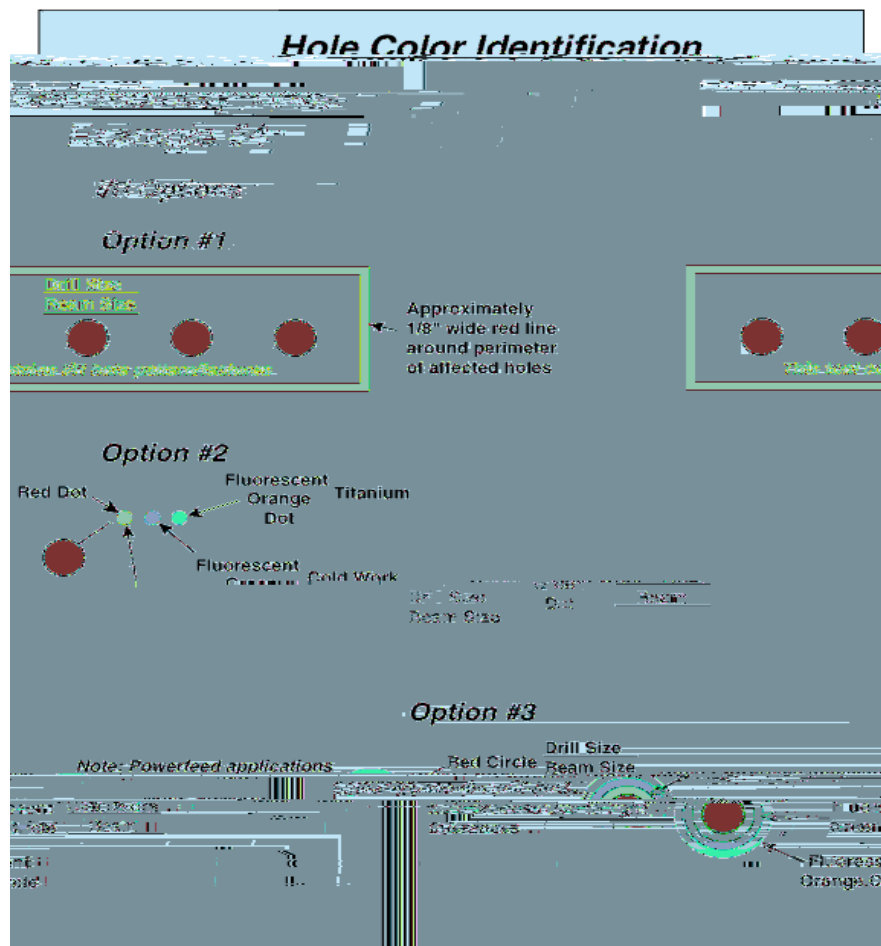

Figure 3. I/R Hole identification Options

proprietary Seller manufacturing processes. Refer to paragraphs 5.1 through 5.3 for inventory/record requirements.

7.0 CONTROL OF BUYER-FURNISHED TOOLS

7.1 Seller shall acknowledge receipt of all tools, including ST, SE, MTE and STE, by the signature of an authorized Representative of Seller on the CPL and return as requested by Buyer.

7.1.1 Seller's Quality Management System ("QMS") shall provide calibration or testing procedures capable of verifying configuration control of Seller-owned or Buyer-furnished Tooling, SE, MTE and STE.

** 7.1.2 Seller's QMS shall include Identification and configuration control procedures for Buyer furnished ST.

** 7.1.3 Seller shall provide verification of compliance upon request from Buyer or Buyer Representative.

7.1.4 Seller shall control tool traceability by ensuring all tool identification labels, plaques and removable details of tool are stored, handled, used and transported appropriately to prevent loss of any Items associated with Buyer furnished Tooling.

7.2 Upon receipt of boxed and sealed tools, Seller shall notify Buyer's Representative to break the seal of the container and visually inspect the tool and contents for completeness and damage. Seller's Quality Assurance (QA) personnel are allowed to open sealed containers in the event that Buyer's Representative is unavailable to support requested program need date(s). Seller shall complete Form FWP-1209 "Tooling Gage Storage Record" accompanying the tool for Fort Worth tools or Form GD1856-1 "Tooling Log Book" for Marietta tools. Seller shall enter discrepancies, if any, in the remarks column. If Seller does not receive the applicable form with the tool, Seller shall initiate an e-SPaR requesting the correct form.

* 7.3 In no case shall Seller attempt to rework, in any manner, Buyer-furnished tooling without prior written authorization from Buyer.

* 7.3.1 Seller shall review Buyer authorization for repair and contact Buyer's Representative to discuss appropriate level of verification or oversight required by Buyer Representative to ensure that rework has been completed.

* 7.3.2 All I/R tooling and tooling used as a media of acceptance shall require delta First Article Inspection ("FAI") demonstrations upon completion of rework or repair, unless the reworked or repaired tool is coordinated to designated control media. Additional I/R and non-I/R repair, preservation and coordination guidance is provided, but not limited to, Part IV of this Manual.

7.3.3 Seller shall initiate a SATR to receive Buyer authorization for both rework and/or repair of Buyer-furnished ST.

7.4 Seller shall maintain the ability to produce the original, or any subsequent Item configuration, including spares, unless changes made by Buyer's engineering are retroactive to the original point of effectivity of Item. Seller shall accomplish this by fabricating other Control Media for its use, or from Buyer-furnished Control Media.

7.5 When Buyer authorizes rework and/or modification and when a tool is capable of producing earlier configurations, Seller shall re-identify the tool to the new configuration Item number. When Buyer-authorized rework and/or modification will render a tool incapable of producing earlier configurations

fixtures. Preservation, storage and shipping container requirements are illustrated in Part IV of this Manual.

10.0 SHIPPING INSTRUCTIONS

10.1 Buyer shall specify destination and mode of transportation for tools that are to be shipped from any point of origin.

- ** Note: Seller shall ensure all Tooling and shipping/storage containers are in usable condition prior to shipment. If either tool or shipping/storage container is not in usable condition, Seller shall initiate an e-SPaR for PO authorization to rework, repair or manufacture a new container and or a SATR for authorization to rework, repair a tool.

10.2 Seller shall provide advance notice to the Buyer's Representative when performing closure of a Control Media container.

- * 10.3 Seller shall contact Buyer's Representative for closure of the Control Media container. If Buyer's Representative is unavailable within two (2) business days to witness the closure of the Control Media container, Seller's QA shall fill out the Form FWP-1209 or GD1856-1 as applicable. Seller's QA and/or Buyer's Representative shall verify the following are complete and included before closure and sealing:

- A. Control Media contents are complete
- B. Applicable surfaces are greased
- C. Loose details, i.e., L-pins, clamps, sub-assemblies, etc., are shored
- D. FWP-1209 or GD1856-1 is stamped and complete

- * 10.4 Prior to shipment, Seller shall note physical damage, if any, to any tool and shall document all such damage, if any, as specified in Part I, Paragraphs 2.12 and 2.13.

10.5 Seller shall use lead seals, steel stamped by Seller, to seal the Control Media container.

10.6 If movement of Control Media will affect Seller's ability to meet a delivery schedule, Seller shall immediately notify Buyer.

- * 10.7 At such time Buyer determines that Buyer-furnished tools located at Seller's facility are to be dispositioned, Buyer shall list the tools and forward the listing, as appropriate, to Seller and Property Management, Subcontract Control Department. Upon receipt of the completed listing, Seller shall process the listed tools as follows:

Segregate the tools to a secured storage area.

Notify Property Management Subcontract Control of the specific location of the segregated tools and indicate the Seller Representative that should be contacted regarding final disposition instructions.

10.8 Upon Buyer's written notification and transfer of tool title from Buyer to Seller, Seller shall remove all evidence of ownership markings from tools and tool containers or render markings unrecognizable. This tooling identification removal includes, but is not limited to, the following:

- Ownership markings on plaques
- Barcodes
- Steel stamping
- Vibro-engrave etching
- Paint markings

Seller shall reference FAR 45.506- Identification for contractor requirements of U.S. Government-owned

property. Seller shall exercise caution to ensure that Tool Code and part number identifications are not removed.

11.0 TOOLING PERIODIC INSPECTION AND VERIFICATION (PI/V)

- * 11.1 PI/V shall be a Seller documented process comprising the cyclical verification of "Selected Tooling" used as a media of acceptance for a feature(s) of an Item. Seller shall document and complete PI/V by a physical coordination to designated Control Media annually. Exceptions to an annual re-verification requirement are defined in 11.5.
- "Selected Tooling" is defined as any Buyer-furnished or Seller-owned tool used as a media of acceptance (inspection) for a feature of any Item deliverable to Buyer, where the feature of the Item established by this tool is not physically measured or inspected by other methods.
 - Example of Selected Tooling that would be placed into a PI/V recall cycle: A Drill Jig (production Tool) used to drill four holes in an aircraft part and subsequently this Drill Jig is also used to verify the same four holes spacing, location, diameter, depth and Seller is not employing any other verification or inspection method to verify these features in the aircraft part.
 - For the purpose of this Manual and specific to PI/V requirements, "annual" is defined as the

performing a tool-to-tool coordination. Tolerance requirements are illustrated in Part IV of this Manual.

12.0 TOOLING PERIODIC INSPECTION AND RE-VERIFICATION (PI/V) RECORDS

- * 12.1 Seller shall maintain a unique record for all tools requiring PI/V. Such record shall list:

- Tool Ownership (LM Aero/ Supplier Owned)
- Buyer or Seller Tool Number
- Buyer or Seller Tool Code
- Buyer-assigned part number
- Next PI/V recall date
- Quality acceptance verification
- Control Media used, if applicable, shall be recorded in the PI/V record
- History of previous PI/V
- Date of PI/V
- PI/V check sheet (if applicable)
- Inactive tools

12.2 Upon Buyer or Buyer Representative's request, Seller shall present the PI/V record.

12.3 Seller shall update or revise the data in its PI/V record to meet the requirements of 12.1 on the next PI/V cycle of each tool.

**** 13.0 BUYER-FURNISHED TOOLING AND SELLER-TO-SELLER TRANSFER OF TOOLS**

13.1 Sellers authorized by Buyer to ship tools to another Seller shall ship tools according to Buyer authorization and Part I, section 10.0 of this Manual.

13.2 Sellers authorized by Buyer to receive tools from another Seller shall re-verify Buyer transferred or Buyer furnished tooling per tool type requirements in PM-4053 in addition to the requirements set forth in this Manual for receipt of tooling in Part I, section 6.0.

13.3 Seller shall utilize the following guidelines for major assembly jigs and gages utilized for assembly as re-verification criteria upon receipt. Conformance to the following criteria, Tool Design drawing, PM-4053 and the specific Jig reference system values shall constitute satisfactory acceptance criteria;

- Visually inspect the jig upon receipt for obvious signs of damage sustained during shipment. All discrepancies or damage shall be documented and submitted to Buyer for rework/repair disposition, via Supplier Aircraft Tooling Report (SATR).
- Continue to locate the jig into position, if applicable, taking care to secure areas of the rough structure and avoid contact with locating features. Verify that the jig rests on all jack screws and jig feet provided.
- Rough level the jig using a conventional optical level and the leveling buttons located along the peripheral rough-structure near each jack screw. Allow the jig to sit over night (24 hours) to normalize to the environmental conditions under its own weight. Temperature and humidity readings shall be documented throughout the process if Laser verification is utilized for this process.
- Remove grease and/or other preservation treatments from the jig and loosen any pins and/or bushings that may have corroded during shipment.

- Install permanent details such as counter-balances, etc., that were temporarily removed for

- Establish periodic inspection points and records for future dimensional stability checks by verifying these key features during this initial set-up process. See Part I, section 11.0 of this Manual for PI/V requirements.
- Verify or install a new DS-228 Tool Identification Tag, if required on all tools per PM-4053, section 3.8. Stamping and dating of Tool Identification Tag shall be accomplished as directed by Buyer Representative.
- Tool shall be placed into use for Trial Run/Tool Proof/FAI activity only.
- Tool shall not be released for Production service until successful Tool proofing activity is completed.

***** END PART I*****

PART II

MANUFACTURED SPECIAL TOOLING- SELLER REQUIREMENTS

- * **1.0 GENERAL** – Part II of this Manual is applicable to all domestic and international Sellers that manufacture, rework or repair ST and is in addition to requirements defined in Part I.
- ** 1.1 Buyer's tool manufacturing specifications are defined in PM-4053. Only Sellers authorized by PO to perform manufacturing, rework or repair are granted access to this Proprietary Data website. Seller shall contact its Buyer for access authorization. See Part I , section 2.15.

2.0 DEFINITIONS

- * 2.1 "REDLINE TOOL DESIGNS" – "Redline Tool Design" is a tool design drawing made by Buyer or Seller which has modifications marked in red ink. Such modifications provide clarification to tool fabrication changes and are known as "Redline Tool Design" changes. The redline change to the drawing is made with the understanding that a formal release incorporating the redline change(s) will be forthcoming. Detailed instructions about "Redline Tool Design" requirements are set forth in PM-4053.
- ** 2.2 Appendix T - is applicable to Non-Recurring Effort ("NRE") Special Tooling and is imposed when Buyer has approved the use of Special Tooling for a purchase order in which Appendix T is specified. Appendix T is located on the Buyers Supply Chain Management homepage, <http://www.lockheedmartin.com/aeronautics/materialmanagement> , under Terms and Conditions.

2.2.1 Seller shall permanently identify all NRE tools as specified in this PO. If specific identification and ownership requirements are defined by this PO, then Seller shall identify NRE tools per the following examples;

- a. Buyer Part Number/Dash Number: Example – 16B1944-29; 5HF45776-103
- b. Buyer Tooling Number: Example - D12345, M081234 or as directed by this PO.
- c. Ownership: Lockheed Martin or U.S. Government (as applicable) by this PO.

- ** 2.3 All Special Tooling covered by this PO, whether furnished to Seller or acquired or manufactured by Seller or its Subcontractor(s), is the property of the Buyer or the U.S. Government and shall not be used in the production, manufacture, or design of any article for any other use, unless the Buyer consents in writing. Buyer shall not consent to the use of Government-owned Special Tooling without prior written U.S. Government consent.

3.0 SPECIAL TOOLING INSPECTION AND QUALITY REQUIREMENTS

- * 3.1 Seller shall comply with stress relief, annealing, welding, and non-destructive inspection (NDI) operations in accordance with PM-4053. Seller shall flow the following instructions in purchase orders to their sub-tiers:

Buyer identification number for Seller
Buyer identification number for Seller's sub-tier (if applicable)
All applicable Buyer-imposed specifications

3.2 Unless otherwise stated in Buyer's Build-to-Package ("BTP"), CMM, theodolite, photogrammetry, calibrated machine probe, and/or laser tracking are the only acceptable methods for contour verification, and are the preferred methods for hole pattern verification. CMM inspection is the overall preferred

method for verification. Exception: if the CMM output data is such that the data is not electronically transmittable to a CATIA model for review, and/or calculations must be performed manually in order to complete the inspection activity (e.g., vector data must be manually calculated for hole locations), the use of theodolites or laser tracking when the data can be readily uploaded electronically to CATIA are then the preferred methods of inspection.

3.3 Inspection Grid Pattern: Unless otherwise stated in Buyer's BTP or specified in PM-4053, Seller shall inspect surfaces requiring verification using the following grid pattern:

3.3.1 A maximum distance of two (2) inches between points along contour for complex and/or compound surfaces. There are no minimum distance requirements.

3.3.2 A maximum distance of six (6) inches between points for planar surfaces. There are no minimum distance requirements.

* 3.4 Seller shall not proceed to the next verification milestone without prior written authorization by Buyer's Representative in the Progressive Inspection Log ("PIL"), or an equivalent log.

3.5 Seller shall establish and/or maintain a quality system which requires the inspection of all dimensions of a tool. Seller's QA shall log all three (3) place dimensions, (2 place for metric) or any dimensions specifically identified for inclusion in Buyer's BTP, into the PIL, but is not required to log one (1) and two (2) place dimensions, (1 place for metric) in the PIL.

3.6 Seller shall include a statement in the PIL to document inspection and acceptance of all one and two place dimensions, (1 place for metric).

3.7 Seller shall document tooling anomalies, requests for deviation or waiver, and other non-conformances, if any, identified during or subsequent to Seller's tool manufacturing and acceptance process by submitting a SATR.

** 3.8 Seller shall plan the following criteria as inspection points and milestones that Seller shall present or provide as verification to Buyer's Representative prior to final acceptance, final approval or final certification, or as otherwise specified by this PO. The following criteria are not all inclusive and shall be reviewed and discussed between Seller and Buyer Representative upon Seller's receipt of this PO.

- Verify closure of all SATRs and E-SPaRs
- Verify 95% Tool Design approval from Buyer, if applicable
- Verify Tool Plaque is stamped in the correct blocks releasing the tool for Trial Run or Production use per PM-4053
- Verify Special Processes, if applicable, are performed per PM-4053, i.e., NDI, Heat Treat, etc.
- Verify paint application per PM-4053
- Verify flow-down of requirements to sub-tier suppliers, if any, per Appendix QX
- Verify, the applicability of a "Delta" FAI or Fit Check requirement for all rework or repair authorizations
- Verify coordination of tool, if applicable, to Control Tools per Tool Design and PM-4053
- Verify all inspection data, electronic and mechanical, have been documented and prepared for shipment with tool, if applicable
- Verify Tool identification is per this PO and/or PM-4053 as applicable
- Verify ownership marking is per this PO and/or PM-4053 as applicable
- Verify loose details are stored and shored per PM-4053
- Verify loose details are identified per program requirements per PM-4053
- Verify I/R markings are per PM-4053 and that Tool Design clearly identifies I/R features and flag notes are used for identifying these features per this Manual in Part II, section 8.0 for production tools

I-R TOOL DESIGN REQUIREMENT'S

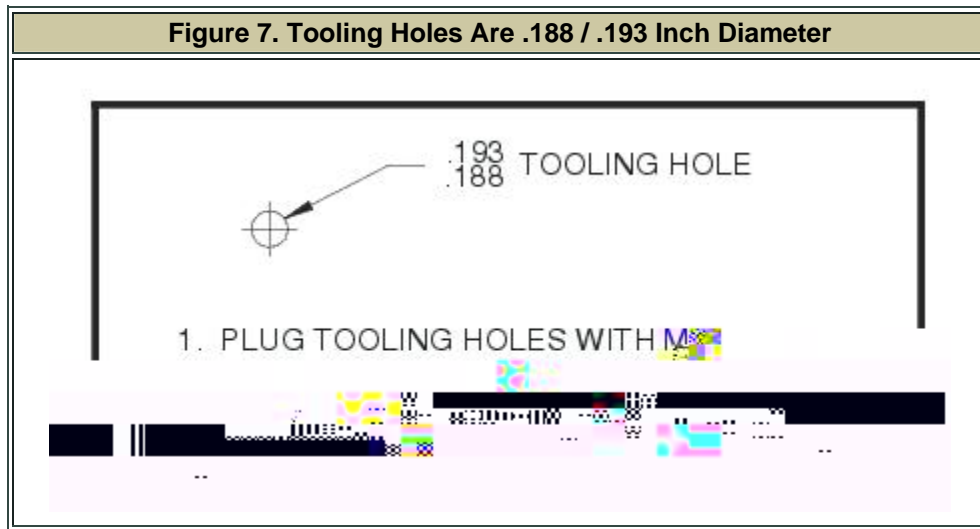

Figure 6. I-R Tool Design Requirements

***** END PART II *****

- * 3.1 Seller shall not rework, repair or in any way alter control tools without prior Buyer written authorization in this PO or in a SATR disposition with a revised CPL and tool drawings, if required, to rework and/or re-stamp control tools.
- * 3.2 Seller shall return to Buyer the stamped and signed Tool Rework Form document and CPL upon completion of Buyer authorized rework or repair.

PART IV APPENDICES



- Maintain allowable production tolerances on interchangeable Items produced/verified with controlled production tooling as illustrated in Figure 8.
- Utilize a check pin for all I/R hole patterns to ensure patterns are made in accordance with the tool coordination tolerance tables included herein.
- Utilize controlled production tooling to check and verify allowable production tolerances on interchangeable Items are from .010 smaller, to .010 larger than the tool, as illustrated in Figure 8.
- Utilize a check pin to check and verify the I/R hole pattern is made in accordance with the tool coordination tolerance tables included herein.

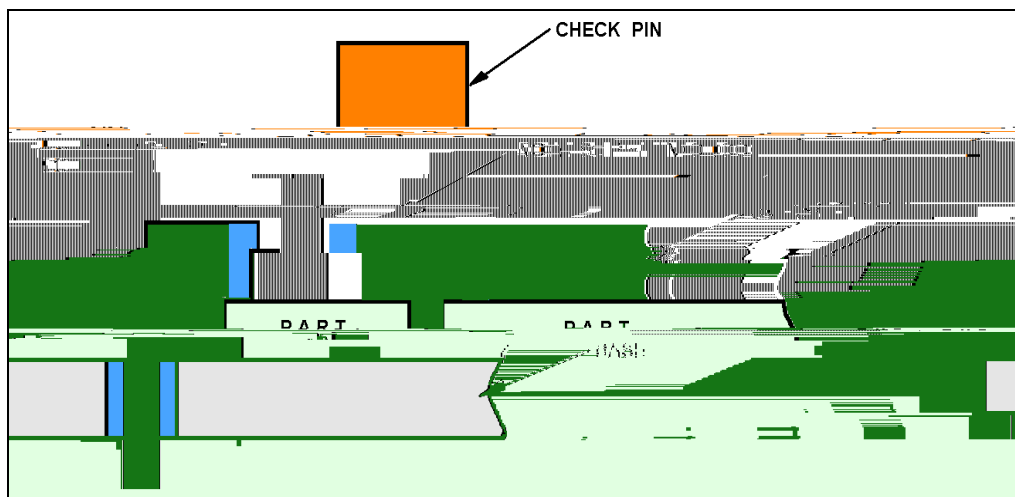

Figure 8. DOUBLE RAIL (INTERCHANGEABLE)

- Verify replaceable and non-I/R part perimeters produced with production trim tools or check fixtures have allowable production tolerances from a maximum of .030 smaller, to a maximum of .030 larger than the tool, relative to the engineering drawing applicable feature tolerance as illustrated in Figure 9 and 10.

- Verify perimeters are plus or minus .030 tolerances, unless otherwise stated on face of drawing. Example: An E.O.P. dimensioned as +.015, -.030 from a F.S., W.L., B.L. would apply. A "Tab" dimensioned as + or -.010 for overall width, would apply if stated on the drawing.
- Utilize a check pin to verify all I/R hole patterns are made in accordance with the tool coordination tolerance table.

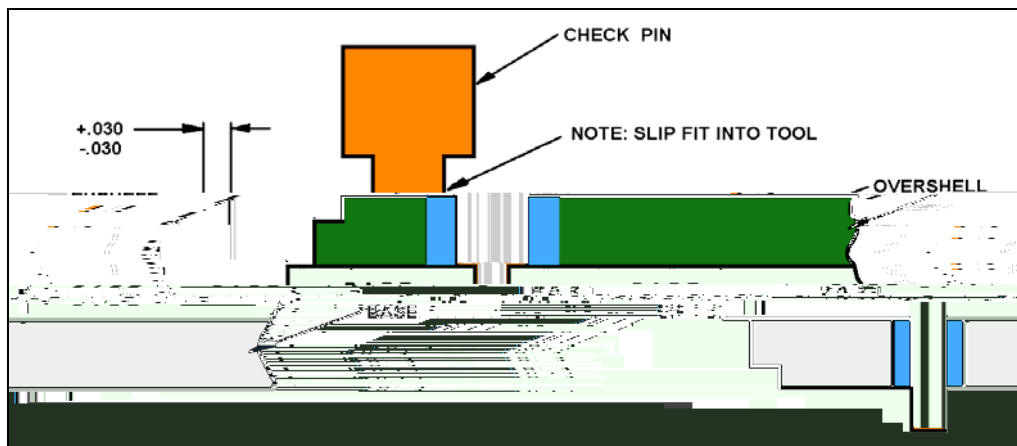

Figure 9. DOUBLE RAIL (REPLACEABLE, AND NON I/R, NET OR WITH EXCESS)

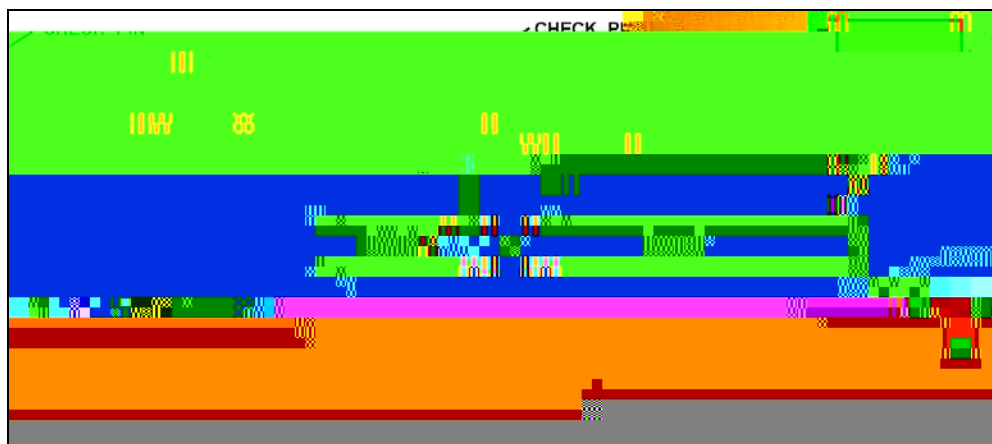

Figure 10. SINGLE RAIL SETBACK TYPE (REPLACEABLE, AND NON I/R, NET OR WITH EXCESS)

- 3.2 For tool inspection requirements of I/R tool coordination (applicable to new make, rework and coordination orders), Seller shall only utilize check pins which are AISI01 tool steel with a heat treat callout of RC 55-65 for pins with a diameter of .2500 or larger, and a RC 38-48 for pins with diameters smaller than .2500.
- 3.2.1 For Control Tool to Production Tool Coordination – Seller shall pin the control tool to the tool being coordinated with .0000 to .0005 undersize pins at four(4) locations reasonably close to the corners of the control tool. Seller shall inspect the remaining holes in accordance with pin tolerances shown in Table 2.0 for “Coordination Check of Control Tools”.
- 3.2.2 For Control Tool to Control Tool Coordination (Make New) – Seller shall install new control tool bushings utilizing pins with +.0000/-.0002 tolerance on diameter (Ref.: Transfer of hole pattern, Table 1.0).

- 3.2.3 For Control Tool to Control Tool Coordination (Rework) – During rework of control tools bushing, Seller shall install bushings utilizing pins with $+.0000/-0.0002$ tolerance on diameter. (Ref.: Table 1.0, Transfer of hole pattern).
- 3.2.4 For Control Tool to Control Tool (Coordination Check Only) – Seller shall check the control tool back to the tool it was made from. During coordination checks of control tools, (Example: MSGA to TOGA), Seller shall pin four corner holes utilizing pins with $+.0000/-0.0002$ undersize diameter. Ninety percent (90%) of the remaining holes are acceptable with $.0000$ to $.0010$ undersize diameter pins and the remaining ten percent (10%) of the holes are acceptable with $+.0000/-0.0025$ undersize diameter pins.
- 3.2.5 For Cross-Coordination of Control Tools – When duplicate control tools are fabricated, Seller shall cross-coordinate control tools in accordance with Table 1.0 "Coordination Check of Control Tools" to ensure compatibility.
- 3.2.6 For Bushing Installation – During the manufacture of new tools and reworks, Seller shall utilize tooling pins with $+.0000/-0.0002$ tolerance to install all tooling bushings (ref.: Table 1.0 and Table 2.0, Transfer of hole pattern).
- 3.2.7 For Inspection of Control Tool Bushing Wear – NOTE: During tool use activities, control tool bushing wear can occur. Seller shall inspect control tool bushings to ensure the maximum wear is limited in accordance with Table 1.0 and Table 2.0. Seller shall not use any control tools where bushing wear exceeds the maximum wear tolerance of $+.0010$ on the inside diameter.

Table 1.0 Coordination Check of Control Tools

HOLES UNDER .250	STRAIGHT PINS	HOLES .250 AND OVER
Nominal $+.0001/+.0004$ Nominal $+.0000/-0.0002$	Transfer of Hole Pattern Bushing I.D. Tolerance Pin Tolerance	Nominal $+.0001/+.0006$ Nominal $+.0000/-0.0002$
Nominal $+.0001/+.0010$ Nominal $-.0015/-0.0020$	Cross Coordination / Coord. Check of Control Tools Bushing I.D. Tolerance Pin Tolerance	Nominal $+.0001/+.0010$ Nominal $-.0020/-0.0025$
STEP PINS		
Nominal $+.0001/+.0004$ Nominal $+.0000/-0.0002$ Nominal $+.0000/-0.0002$.0005 Max	Transfer of Hole Pattern (New Make) Bushing I.D. Tolerance Lg. Dia. Pin Tolerance Sm. Dia. Pin Tolerance Concentricity	Nominal $+.0001/+.0006$ Nominal $+.0000/-0.0002$ Nominal $+.0000/-0.0002$.0005 Max
Nominal $+.0001/+.0010$ Nominal $-.0000/-0.0002$ Nominal $-.0015/-0.0020$	Cross Coordination / Coord. Check of Control Tools Bushing I.D. Tolerance Lg. Dia. Pin Tolerance Sm. Dia. Pin Tolerance	Nominal $+.0001/+.0010$ Nominal $-.0000/-0.0002$ Nominal $-.0020/-0.0025$

Table 2.0 Coordination Check of Production Tools

HOLES UNDER .250	STRAIGHT PINS	HOLES .250 AND OVER
Nominal +.0001/+.0004 Nominal +.0000/-.0002 Nominal +.0001/+.0004	Transfer of Hole Pattern (New Make) C/T Bushing I.D. Tolerance Pin Tolerance P/T Bushing I.D. Tolerance	Nominal +.0001/+.0006 Nominal +.0000/-.0002 Nominal +.0001/+.0006
Nominal +.0001/+.0010	Coordination Check of Control Tools to Prod. Tools Bushing I.D. Tolerance	Nominal +.0001/+.0010
	STEP PINS	
Nominal +.0001/+.0004 Nominal +.0001/+.0004 Nominal +.0000/-.0002 Nominal +.0000/-.0002 .0005 Max	Transfer of Hole Pattern (New Make) C/T Bushing I.D. Tolerance P/T Bushing I.D. Tolerance Lg. Dia. Pin Tolerance Sm. Dia. Pin Tolerance Concentricity	Nominal +.0001/+.0006 Nominal +.0000/-.0006 Nominal +.0000/-.0002 Nominal +.0000/-.0002 .0005 Max
Nominal +.0001/±.0010	Coordination Check of Control Tools to Prod. Tools Bushing I.D. Tolerance	Nominal +.0001/±.0010
Nominal +.0000/-.0002 Nominal +.0001/+.0004 .0003	Additional Production Tool Tolerances O/D of Slip Bushing I/D of Slip Bushing Concentricity O/D to I/D	Nominal +.0000/-.0002 Nominal +.0001/+.0006 .0003
Nominal +.0000/-.0002 Nominal -.0010/-.0012 .0005 Max	Hinge Line Tool Tolerances Pins for End Hinges Pins for Middle Hinges Concentricity (end & middle)	Nominal +.0000/-.0002 Nominal -.0010/-.0012 .0005 Max

3.3 Seller shall utilize step pins, as illustrated in Table 3.0, to perform a verification check of production items to production tools. Seller shall ensure the check-pin diameter is made to the low engineering range of the hole diameter being checked with the pin diameter tolerance as shown in Table 3.0.

